

DEUTSCHE™

BEVERAGE + PROCESS



Deutsche CIP Skid User Manual

9.5.23 Revision
Deutsche Beverage + Process
704-900-6606

Table of Contents

Introduction and Safety – pg. 2
CIP Skid Components – pg. 3
Installation – pgs. 4-5
HMI Overview – pgs. 6-10
System set-up and commissioning – pgs. 11-12
Calibration – pg. 12
Automation and Recipe Set-up – pg. 13
Manual modes – pgs. 14 and 15
Maintenance, troubleshooting and spare parts – pgs. 15-17

INTRODUCTION

This manual contains installation and operation instructions for the Deutsche CIP Skidded Systems.

ABOUT THIS MANUAL

This manual covers the complete line of CIP skidded systems including both 3 and 4 vessels and 1 and 2 circuits. All CIP skids are available with optional equipment that can provide additional functionality.

Please contact **Deutsche Beverage at 704.900.6606** for assistance.

APPLICATION

Deutsche's CIP skid regulates the operation of your Clean-in-Place processes. The CIP skid takes the guesswork out of configuring and controlling the start, stop, flow, temperature, and chemical concentrations required for a successful clean in place cycle. If used properly, your CIP skid can be a source of savings and a vital step in ensuring product quality through rapid and effective cleaning.

TECHNICAL DATA

Compressed air pressure: 70-90 psig

Air inlet size: 1/2" FNPT and 1/2" TC

Product temperature range: 0°F–185°F

Electrical requirement: 208V 3 Phase or 480 3 Phase Power

Amperage requirement based on system configuration

Steam supply based on system configuration

Water inlet size: 1.5" MNPT or TC

DISCLAIMER OF LIABILITY

Deutsche does not assume responsibility and expressly disclaims liability for loss, damage, or expenses that arise in any way from the installation, operation, use, or maintenance performed in accordance with this manual.

Deutsche reserves the right to make changes to the product, specifications, or this manual without prior notice.

Safety

This manual includes essential information for installing, operating, and maintaining equipment properly and in a safe manner. Failure to do so could result in personal injury and/or equipment damage.

DO NOT attempt to remove and/or modify the CIP skid hardware or programming. Doing so can create unsafe conditions for operator(s) and surrounding persons. Changes to Deutsche products or programming void all warranties.

DO NOT place the CIP skid in an application where general product service ratings are exceeded. Doing so puts operator(s) and surrounding persons at risk of personal injury and may result in equipment damage.

E-STOP CAPABILITY

1. Activate E-Stop to turn off all operations.
2. To release the E-Stop, twist clockwise until it pops up. To re-activate system, press the blue E-stop re-set button

Chemical Safety

1. **CIP cleaning chemicals are naturally dangerous!**
2. Always refer to your chemical providers safety data sheets for any chemicals used in your facility

CIP Sizing and Components

CIP Skid Basics

Deutsche CIP Skids are available in 50gal, 100gal, 125gal, 150gal, and 200gal models. Sizing is dependent on application, distance, and size of equipment to be cleaned, header size, etc. 3 or 4 vessel systems can be chosen based on cleaning schedule and chemicals used. 1 or 2 circuit systems add an additional supply and return pump, to allow 2 cleaning cycles to run concurrently. Each circuit has its own temperature and conductivity loop.

CIP Skid Components

*Image is a 125gal, 2 circuit, 4 vessel skid. Other options available upon request.

1. Control Panel
2. HMI
3. Batch Chemical Holding Tank
4. Thermaline Heat Exchanger
5. Pulsafeeder E+ Chemical Dosing Pumps
 - a. The smaller 1.9 LPH pump is for PAA or sanitizer
 - b. The larger 94.6 LPH pumps are for caustic and acid chemicals
6. SPX C-Series Centrifugal Supply Pump
7. IFM TD2263 Tank Temperature Probe
8. IFM PI2797 Level Sensor
9. IFM TD2843 Supply and Return Temperature Probe
10. IFM LDL201 Conductivity Sensor
11. E&H Promag H100 Flowmeter
12. E&H Orbisent Memosens PH Electrode
13. SPX Pneumatic Valves

Not Shown

14. SPX Ws+ Self-Priming Liquid Ring CIP Return Pump mounted in the field
15. Granzow 8000-00T Pneumatic Steam Valve mounted in the field
16. Barrels of chemicals provided by customer. Typically placed on pallet adjacent to skid

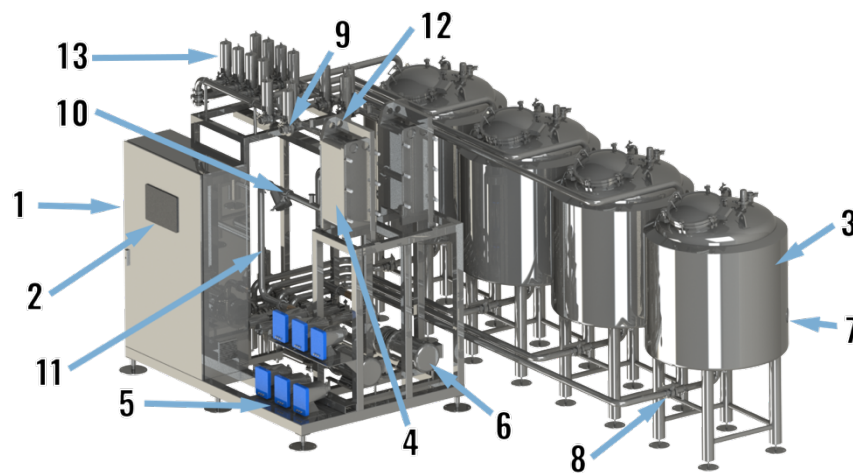

Installation

The CIP control cabinet arrives mounted to the skid and pre-wired to instruments installed on the skid. Typical installation requires a dedicated 208V or 480V 3-Phase with enough amperage for the configuration. Electrical schematics provided with the control panel indicate location, voltage, and amperage requirement for the panel. The skid will ship with the holding tanks, connecting piping, and 3-4 tank auto valves separate, requiring some initial assembly detailed below.

Warning! To avoid electrocution, ALL electrical work should be done by a registered electrician, following industrial safety standards and local codes. All power must be OFF and safely locked out during installation.

Tank and Pipe Installation

1. Place CIP skid in desired location. Review location with Deutsche Beverage project manager to ensure final placement.
2. Level the system using the threaded foot pegs on the bottom corners and middle of the skid.
3. Place the 3 or 4 batch chemical tanks according to the approved Deutsche Beverage layout.
4. Level the individual tanks and place the footplates underneath each peg.
5. Unwrap and attach piping and valves from the tanks to the CIP skid.
 - a. Install 1 ea. SPX pneumatic valve on top of each batch chemical tank on the water inlet. Confirm location with Deutsche project manager
 - b. Air tubing for each valve is labelled and hanging on the skid. Attach each corresponding air tube to each pneumatic valve by referring to the field wiring drawings located inside the panel
 - c. Each pipe and tank ferrule connection will be labelled with a V## or a C##. The number on the pipe should correspond with the number on the tank, pipe, or valve where the connection is to be made.
 - d. Use a sanitary tri-clamp and gasket to make these connections.
6. *If pipes are difficult to attach, verify equipment is in the exact place and level. If equipment is not placed correctly, piping will not line up!*

Level and Temperature Sensor Install

1. Each chemical batch tank has 1 ea. IFM PI2797 level sensor and 1 ea. IFM TD2263 temperature probe.
2. Deutsche to provide these instruments as well as their mounting hardware.
3. IFM PI2797
 - a. Attaches to the open 1.5" TC Ferrule on the bottom of the tank outlet piping.
 - b. Ships and installed with a E33208 TC adapter and gasket
 - i. Install gasket, thread adapter to fitting, and install to TC ferrule on tank drain line with sanitary Tri-clamp fitting and gasket
 - c. Refer to field wiring drawing inside the control cabinet
 - i. Each sensor will have an un-attached orange IFM cable already tied to the skid. Check labelling on hanging orange cable and plug into corresponding level sensor.
4. IFM TD2263
 - a. Attaches to threaded 1/2" FNPT on side of each chemical batch tank
 - b. Ships and installed with a UT0038 Compression fitting
 - i. **Lightly coat 1/2" MNPT of the adapter with anti-seize lubricant** and thread into the tank, lightly tightening (1/4 turn) with a wrench
 - ii. Feed TD2263 probes through the compression fitting until the probe bottoms out. Tighten the compression nut just past hand tight
 - c. Refer to field wiring drawing inside the control cabinet
 - i. Each sensor will have an un-attached orange IFM cable already tied to the skid. Check labelling on hanging orange cable and plug into corresponding level sensor.

CIP Return Pump Install

1. Place CIP return pump in the field at location determined by Deutsche equipment layout
2. Level the pump using the three feet
3. Refer to field wiring drawings located in the control cabinet or contact your Deutsche project manager.
4. Attach 3 phase wire and conduit to pecker-head on pump and land each wire in the control panel according to panel drawings

Utility Connections

1. Incoming Building Power
 - a. 3 Phase, 208V or 480V, 60HZ – ***confirm voltage with project manager!***
 - b. Amp Load depends on voltage, application, and skid size. Refer to field wiring drawings or Deutsche project manager to confirm
 - c. Refer to field wiring drawings within the control panel for location and cable specs for landing incoming building power
2. Steam
 - a. Low pressure (10-15 psi steam)
 - b. BTU load is dependent on application, skid size, and number of circuits. Please confirm with Deutsche project manager before sizing your boiler
 - c. Steam connection is 1.5" TC.
 - d. *The skid ships with 1 Granzow G8000-00T air actuated steam valve (per circuit). This valve should be installed on the steam line prior to the connection to the skid's control panel.*
3. Water
 - a. City water should be attached to the 2" water header above the batch chemical holding tanks
 - b. Recommended minimum 10 GPM inlet water supply will fill each tank in 5-20 minutes depending on tank size
 - c. 1.5" MNPT threaded attachment for incoming water supply
4. Compressed Air
 - a. Air manifold connection 1/2" NPT Female
 - 70-90 psi, <5 CFM
 - b. Blowdown air connection 1/2" TC (1/circuit)
 - 0-100 PSI Regulator required
 - Pressure setpoint may vary depending on length of pipe, header size, and distances to tank
5. Chemicals
 - a. The CIP skid arrives with some PVC tubing and an inlet valve and strainer assembly for each dosing pump suction to drop in customer provided chemical barrels. More may be required depending on chemical barrel positioning
 - i. Caustic and acid dosing pumps use 1/2" ID PVC tubing
 - ii. PAA and Sanitizer pump use 1/4" ID hard polyethylene tubing
 - b. **Ideally, the pump suction tubing is inserted into 55 gal chemical drums adjacent to the CIP skid**
 - i. **The suction tubing should be trimmed to where the foot valve sits vertically, 1/2" above the bottom of the chemical drum.**
 1. **Poor priming performance, especially of the PAA or sanitizer pump can occur if the suction tubing is excessively long or foot valve is not appropriately positioned**

OPERATION

**Deutsche project manager must be on site for commissioning of the system prior to turning the system on. If the system is turned on prior to Deutsche project manager being on site, all warranties will be voided.*

CONTROL PANEL

Use the touchscreen on the control panel to select cleaning cycle parameters. Operators should take a moment to familiarize themselves with the items in bold below.

Screen Overview

Main Screen

1. **Alarms:** Notices for any system alarms including high temperature, level, conductivity, and e-stop
a. E-Stop Alarm must be re-set prior to starting any process on the CIP system
2. **Trending:** Log of all instrument and motor data over a 2 and 12 hour period. Purpose is data collection and troubleshooting
3. **Settings:** Password protected inputs, **Master Data Setpoints**, PID loop configurations, touch screen calibration, time and date screen, alarm setpoints, email notifications, instrument configuration

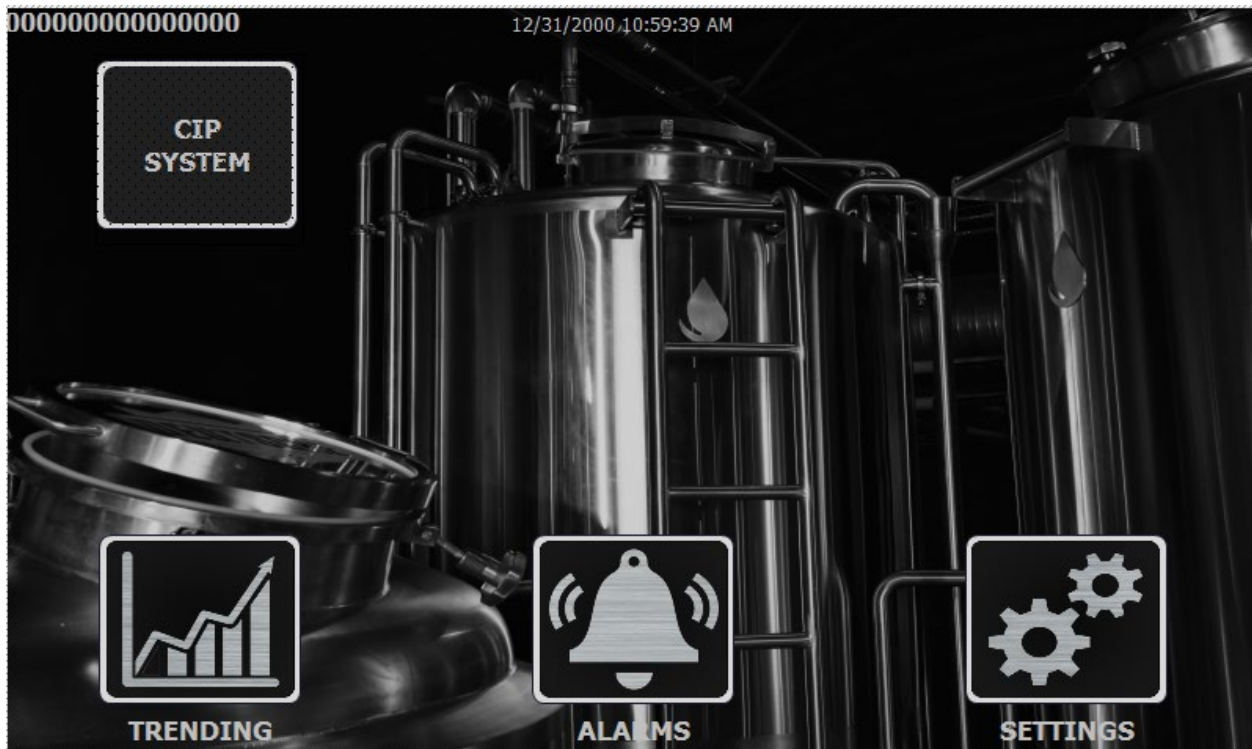

CIP System

1. Automation Control Screen - Primary operator interface for completing cleaning cycles

The image displays two screenshots of the 'AUTOMATION CONTROL' interface for a CIP system. Both screens show a top header with '0000000000000000' on the left, 'AUTOMATION CONTROL' in the center, and '12/31/2000 10:59:39 AM' on the right. Below the header is a 'START OPERATION' section with 'START', 'PAUSE', and 'RESET' buttons.

The main interface is divided into six vertical panels:

- GENERAL SETPOINTS:** Includes 'AUTO' (top), 'FLOW RATE: 000.0 gal', 'MIN CIRCUIT VOLUME: 000.0 gal', 'RETURN PUMP TIMER: 00.0 min', and 'RECIPE DATA OFF'.
- BLOW DOWN CYCLE:** Shows 'OFF'.
- RINSE CYCLE:** Shows 'PRE-RINSE OFF', 'CIRCULATION TIME: 000.0 min', 'REUSE STATUS OFF', and 'REUSES LEFT 0'.
- CAUSTIC CYCLE:** Shows 'OFF', 'CIRCULATION TIME: 000.0 min', 'REUSE STATUS OFF', and 'REUSES LEFT 0'. A green 'CHEMICAL BATCH READY' indicator is visible at the bottom.
- ACID CYCLE:** Shows 'OFF', 'CIRCULATION TIME: 000.0 min', and a green 'CHEMICAL BATCH READY' indicator at the bottom.
- SANITIZER CYCLE:** Shows 'OFF', 'CIRCULATION TIME: 000.0 min', and 'POST RINSE INACTIVE'.

At the bottom of each screen are navigation buttons: 'RECIPE SETPOINTS', 'NOTES', 'MAIN', 'ALARM', 'SENSOR DATA', and 'PAGE CONTROL'.

2. **Auto Calibrate** Screen – Used during commissioning, when a new chemical is introduced to the system, or a change in system settings

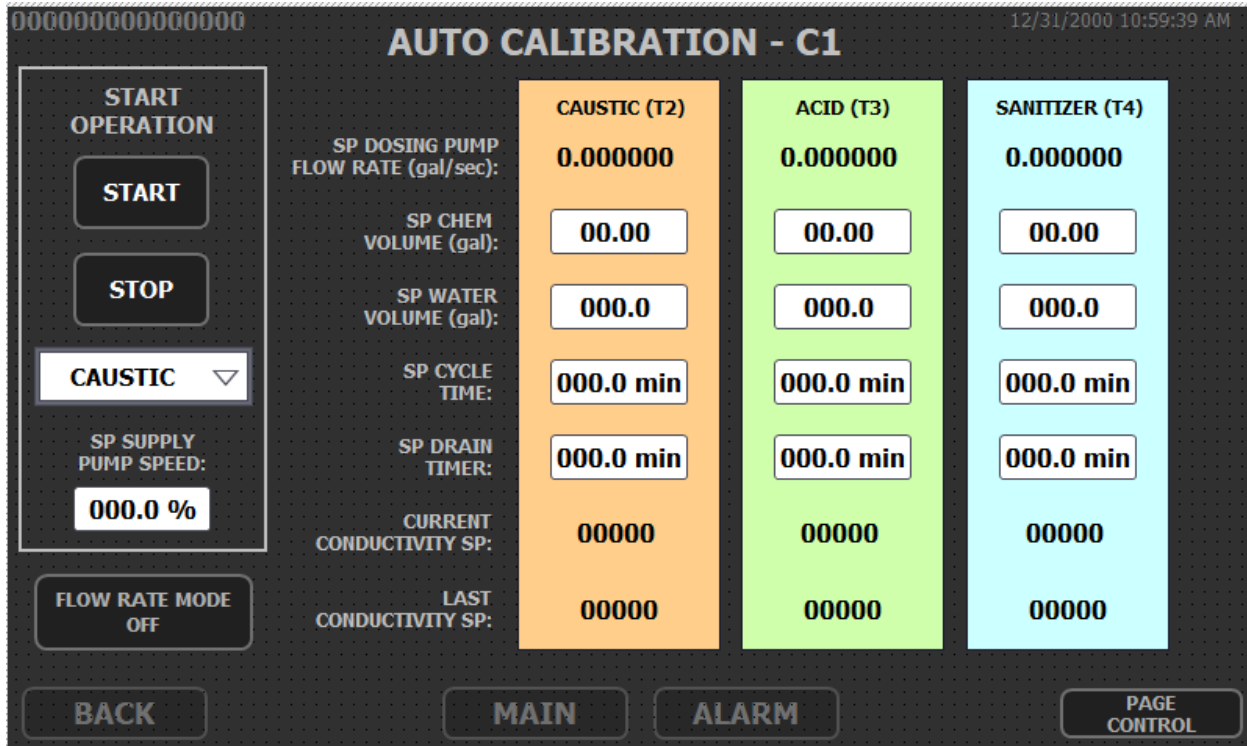

3. **Motor Overview** Screen – Quick links to all dosing pump motors and supply and return pump motors for 1 or both circuits. Can check motor status, run in manual, or troubleshoot
4. **Valve Overview** Screen – Shows status of all pneumatic process valves on the system. Can manually open and close valves from this page, or place them back in auto-mode
5. **Page Control** - a quick reference to all the HMI screens
6. **Chemical Setpoints** Screen – Update basic chemical solution setpoints like conductivity, temperature, re-use limits, post rinse time, all based on chemical data sheets. These will be held standard across all caustic, acid, or sanitizer cycles. [These are likely to remain constant depending on facility cleaning procedures. Acid passivation may require a change in settings](#)

00000000000000000000 **BASE CHEMICAL SETPOINTS** 12/31/2000 10:59:39 AM

PRE RINSE	TEMP (degF)	000.0 F	CAUSTIC	TEMP (degF)	000.0 F	ACID	TEMP (degF)	000.0 F	SANITIZER	TEMP (degF)	000.0 F
	TIME	0.0 min		HIGH TEMP STEAM SHUT OFF	000.0 F		HIGH TEMP STEAM SHUT OFF	000.0 F		HIGH TEMP STEAM SHUT OFF	000.0 F
POST RINSE	REUSE	NO	CAUSTIC	CONDUCTIVITY	00000	ACID	CONDUCTIVITY	00000	SANITIZER	CONDUCTIVITY	00000
	REUSE LIMIT	00		REUSE	NO		REUSE	NO		REUSE	NO
		AUTO CALIBRATION			POST RINSE TIME (min)			POST RINSE TIME (min)			POST RINSE TIME (min)
		CONDUCTIVITY SETPOINTS			000.0 min			000.0 min			000.0 min
					POST RINSE TEMP (degF)			POST RINSE TEMP (degF)			POST RINSE TEMP (degF)
					000.0 F			000.0 F			000.0 F

CHEMICAL CONDUCTIVITY SETPOINT

**NOTE:
CONFIRM CONDUCTIVITY
WITH CHEMICAL MANUFACTURER**

CONDUCTIVITY MEASUREMENT: $\mu\text{S/cm}$

CAUSTIC		SP USED:
AUTO CALIBRATED SP:	00000	<input type="button" value="AUTO"/>
MANUAL SP:	<input type="text" value="00000"/>	<input type="button" value="MANUAL"/>

ACID		SP USED:
AUTO CALIBRATED SP:	00000	<input type="button" value="AUTO"/>
MANUAL SP:	<input type="text" value="00000"/>	<input type="button" value="MANUAL"/>

SANITIZER		SP USED:
AUTO CALIBRATED SP:	00000	<input type="button" value="AUTO"/>
MANUAL SP:	<input type="text" value="00000"/>	<input type="button" value="MANUAL"/>

- Master Setpoints** Screen – Standard setpoints and timers used across all cycles. These are likely to remain constant depending on facility cleaning procedures

0000000000000000 12/31/2000 10:59:39 AM

MASTER DATA SETPOINTS

	TANK LEVEL (inch)	TANK TEMP TIMER (min)	DOSING COND TIMER (min)	BATCH READY RESET DB (degree)	DOSTING PUMPS	
					OFF CYCLE TIME (sec)	ON CYCLE TIME (sec)
PRE/POST	000.0	000.0				
CAUSTIC	000.0	000.0	000.0	00.0	000	000
ACID	000.0	000.0	000.0	00.0	000	000
SANI	000.0	000.0	000.0	00.0	000	000
<hr/>						
	BLOW DOWN TIMER (min)	DEPRESS TIMER (min)	SYSTEM DRAIN TIMER (min)		STEAM VALVE OFF TEMP DIFF (degree)	
C1	000.0	000.0	000.0		00.0	

NOTE: TANK TEMP TIMER NEEDS TO BE LONGER THAN DOSING COND TIMER

BACK
MAIN
ALARM
PAGE CONTROL

- T1 Flowchart** Screen – Visual of Tank 1's circuit and operation. Includes Auto-fill button for T1
- T2 Flowchart** Screen – Visual of Tank 2's circuit and operation. Includes Auto-fill button for T2
- T3 Flowchart** Screen – Visual of Tank 3's circuit and operation. Includes Auto-fill button for T3
- T4 Flowchart** Screen – Visual of Tank 4's circuit and operation (*only on 4 vessel systems*). Includes Auto-fill button for T4

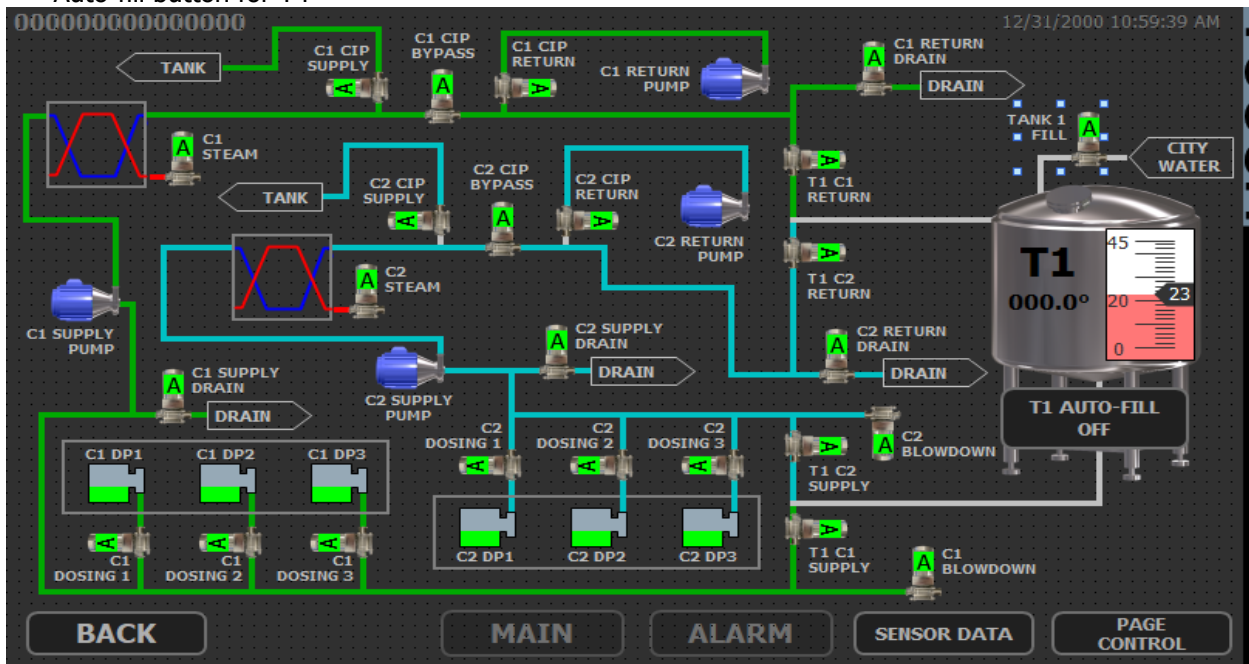

System Set-up and Commissioning

During commissioning, the system owner/operator and Deutsche representative are to complete the following checklist. Owner/operator to have electrician and mechanical contractor available on site to fix any discrepancies found on this list.

1. Verify incoming power is within spec _____
2. Verify tanks are level _____
3. Verify piping connected to tanks and all TC connections are tight _____
4. Verify tank pneumatic valves mounted and connected with air tubing _____
5. Verify IFM level and temperature sensors attached and wired correctly _____
6. Verify compressed air supply active and attached to blowdown and manifold _____
7. Verify steam line is attached with valve in line and attached with air tubing _____
8. Verify water is active and hooked up to header above the chemical batch tanks _____
9. Check for air leaks by manually operating valves _____
10. Check for loose wires and flipped breakers within the control panel _____
11. Check motor rotation for supply and return pump(s) _____
12. Manually operate all valves, pumps, sensors and confirm point to point function checks _____
13. Label all chemical pumps and make sure correct chemical drum is attached to each pump _____
14. Verify all dosing pumps are at 100% stroke length and 100% stroke rate on the individual pump control panel _____

*a. The dosing pump settings must remain constant for consistent dosing. If you change a setting on a pump, you **MUST** recalibrate your system.*

Project Manager Name: _____ Date: _____

Owner/Operator Name: _____ Date: _____

1. Input data in **Master Setpoints** page
 - a. **Tank Level:** Minimum water level in batch chemical tank before starting a cycle
 - b. **Tank Temp Timer:** Minimum time batch chemical tank will circulate at temperature setpoint before pushing solution to the tank to be cleaned
 - c. **Dosing Cond Timer:** Minimum time batch chemical tank will circulate at conductivity setpoint before pushing solution to the tank to be cleaned
 - i. **Dosing Cond Timer** must be set lower than tank temp timer to ensure both setpoints are met prior to moving to next step in process
 - d. **Tank Drain Timer:** Standard time to empty a tank after a rinse or cleaning cycle. Only occurs after the re-use limit is reached, or if re-use is not selected.
 - e. **Blow Down Timer:** Standard time to open blow down valve and drain to allow system to purge
 - f. **Depress Timer:** Standard time after the blowdown to leave drains open and depressurize the system
 - g. **Batch Ready DB:** Degrees below temperature setpoint based on specific chemical batch on chemical setpoints page. If temp drops below this setpoint after a batch is ready, the batch will require re heating.
 - h. **Dosing Pump off/on Cycle:** During final dosing stages, the chemical pump will dose for the "On Cycle" value, and pause for the "Off Cycle" Value until the desired conductivity is reached
 - i. **Steam Valve Off Temp Diff:** The steam valve will automatically close at the tank temperature setpoint minus this value to prevent overheating
2. Select the C1 Return pump and input a value in the No C1 Supply Pump Auto Speed SP
 - a. This is the speed the return pump will run to empty the cleaning solution from the cellar tank
3. Input data in **Chemical Setpoints** page
 - a. **Re-use limit** counts each cycle, and dumps the solution to drain after the re-use limit is reached
 - i. *Contact chemical provider for common re-use practices for each chemical*

- b. Take extra-caution matching **TEMP** to the desired temperature on the chemical safety data sheet provided by chemical provider
- c. **High Temp Shut Off** will close steam valve if temperature of a solution rises too far above a setpoint. Best practice to set this just below max temperature recommendation of each chemical solution
- d. **Rinse Time** is how long a rinsed step will circulate before moving to the next step. Rinses can be recaptured or dumped based on user input
- e. **Pre-Rinse Time** is the amount of time circuit will push rinse water to the cellar tank, and then to the drain. This water is not recaptured into the system. If the timer is set greater than the volume in the tank, the system will stop the rinse and move to the next step
- f. **Conductivity** can be manually inputted from chemical supplier data, or calibrated using the auto-calibrate function. We recommend using chemical data when available. Some chemicals with low conductivity may not have this data available and require the auto-calibrate function. Always verify the conductivity inputted is in microseimens/cm unit and double check it is entered properly. [Deutsche is not liable for misuse and damage to tanks due to high conductivity setpoints!](#)

Dosing Pump Calibration

Caution: Follow PPE requirements found on chemical safety data sheets provided by chemical provider.

Verify water, power, air, and steam are all in operating condition

Materials needed for calibration step: 0:50lb range scale, 5 gallon bucket for water or dosing chemical, PPE, A scale with a smaller range may be needed for accurate PAA or sanitation chemical calibration (0.00 significant figures)

Calibration is recommended every 6 months or anytime a new chemical is used.

**Calibration is not recommended if chemical supplier can provide conductivity values to be manually inputted. See above 2. f.*

1. Prime dosing pump with water by opening designated dosing pump pneumatic valve, CIP skid drain valve. Select dosing pump on the **Flowchart**, Manual mode, and start until suction and discharge tubing is full of water.
2. On the main screen touch CIP System>Page Control>Auto Calibrate
3. Select chemical dosing pump to be calibrated in the drop down menu
4. Activate flow rate mode by pressing **Flow Rate Mode off** on the bottom of the screen
5. Weigh water or chemical solution to be dosed in 5 gal bucket
 - a. *Weighing chemical solution instead of water will result in most accurate calibration if you have the necessary PPE and material to weigh and pump safely*
6. Input chemical **start weight** (lbs) in the pop-up window
7. Insert chemical pump suction tube into bucket
8. Press **start**
9. Weigh remaining water or chemical solution in the bucket and input data into **final weight**
10. If using chemical solution, input chemical density. If using water, input 8.314 lbs/gal
11. Press **Save** to update dosing pump flowrate
12. Close out the flowrate mode pop-up window
13. Input chemical volume – **SP CHEM VOLUME** into the **auto calibrate** page. This is determined by the desired concentration shown on your chemical data sheet. If 1% concentration and 15 gallons of water to be transferred for calibration, 0.15 gallons of chemical should be the chemical volume input.
14. Press **start**
15. During this step the system will automatically pump chemical volume, read, and save the conductivity value, and complete a rinse of the skid

16. Once complete, repeat steps 2-9 for any other chemicals to be calibrated by selecting new chemical and dosing pump in the drop down menu
17. **SP Supply Pump Speed** is confirmed during commissioning and should remain constant during calibration steps to ensure consistent dosing is achieved.
18. Do not start another process until you are sure no other processes are ongoing! Auto-calibrate includes a clean-out and drain time to make sure pipes are empty between steps

Automation Control Page Set-up

1. On the main screen touch **CIP System**
2. **Min Circuit Volume** is the amount of chemical solution to be pumped to a tank to be cleaned before the return pump will start
 - a. *This should be set based on the furthest and largest tank away from the skid to ensure there is some liquid level in the cellar tank before turning on the return pump. This input should be tuned during start-up of the system and likely unchanged once set up appropriately.*
3. **Flow Rate** input is gallons per minute the feed pump will supply to the cleaning circuit
 - a. General flowrate setpoints:
 - i. 50 Gal–20 GPM, 100 Gal–35 GPM, 125 Gal–45 GPM, 150 Gal–55 GPM, 200 Gal–70 GPM
4. **Circulation Time** is the amount of time a specific chemical solution will circulate the desired tank before completing a rinse and moving to the next cleaning step
5. **Return Pump Time** is how long the CIP return pump runs after completing a circulation time. This can vary based on the size of tank to be cleaned, as well as the distance from the CIP skid
6. **Recipe Setpoints** allows different saved circulation times, flowrates, concentrations, and setpoints to be recalled depending on the tank or type of cleaning cycle
7. To activate recipe data, select **recipe off** button to turn recipe data on
8. **Pre-rinse** activates an initial rinse cycle using water recaptured water from a previous cycle. The pre-rinse automatically goes to the drain if activated. If pre-rinse is not activated, the process will start with caustic cycle or whichever cycle is selected first in the sequence
9. After each chemical cycle, the system will automatically complete a rinse cycle. The time and re-use limits for these rinses can be set on the **Chemical Setpoints** Page

Recipe Setpoints Page

1. On the main screen touch Page Control>Automation Control>Recipe Setpoints
2. Create a new recipe by naming and numbering the recipe using the top dropdown menu
 - a. Creating a tank by tank recipe page, a heavy, medium, or light duty recipe, or different vessel size recipe are some of the ways to utilize this feature
3. Input desired setpoints for the specific tank recipe
 - a. "FLOW_RATE" is supply pump gallons per minute
 - b. Select 1 for Pre-rinse if you would like the skid to complete a pre-rinse of the tank
 - c. "MIN CIRCUIT VOLUME" is the amount of chemical solution to supply the tank before turning on the return pump. The further away the tank, the larger this amount may need to be to fully fill the circuit
 - d. "RETURN PUMP TIMER" is how long the return pump will run after a circulation to fully empty out the tank being cleaned. This setting can change based on size of tank and distance from skid
 - e. Select 1 for "CAUSTIC" if you would like system to perform caustic cycle
 - f. Input CAUSTIC circulation time

- g. Select 1 for "ACID" if you would like system to perform acid cycle
 - h. Input ACID circulation time
 - i. Select 1 for "SANITIZER" if you would like system to complete a sanitation cycle
 - j. Select 1 for "SANITIZER POST RINSE" if your sanitizing chemical requires it (Common for PAA)
 - k. Save recipe by pressing save button (second from the left on the bottom of the screen)
 - l. To select a recipe to use for cleaning, select tank recipe from dropdown menu, and press the **transfer** button on the bottom right of the recipe input page.
 - m. Verify correct data has populated on the **Automation Control** page
4. CIP Skid automatically will perform rinses between each cycle as noted on "Automation Control" page. Rinse times can be adjusted on the **Chemical Setpoints** screen.

Manual Modes

All pumps and valves can be operated manually via the motor overview, valve overview, or flowchart pages. Select the valve or pump to operate and place in manual close or open. Make sure necessary valve routes are open before starting a pump.

**Always open the drain line valve and dosing valve when running the dosing pumps in manual mode to prevent damaging the pump*

There are 2 "manual" mode options – manual cycle or manual batch

Manual cycle will complete only the selected rinse or chemical step by circulating the chemical at desired setpoints through the tank to be cleaned. It will return the chemical, or dump if the re-use limit is reached. This feature is useful for a quick rinse or an extra caustic only cycle, without going through a fully automated multiple step process. This step does not complete any pre or post rinses, only the selected cycle.

Manual batching will only circulate through the skid only by going through the bypass loop/valve and make a batch of solution at the desired conductivity and temperature, before stopping. This does not automatically push a solution forward to a tank or process. This allows you to manually pump a solution to a plant system that does not communicate to the CIP return pump. This feature is ideal for circulating through process lines that do not empty into a tank, or another tank that is further away and not connected to the master CIP circuit.

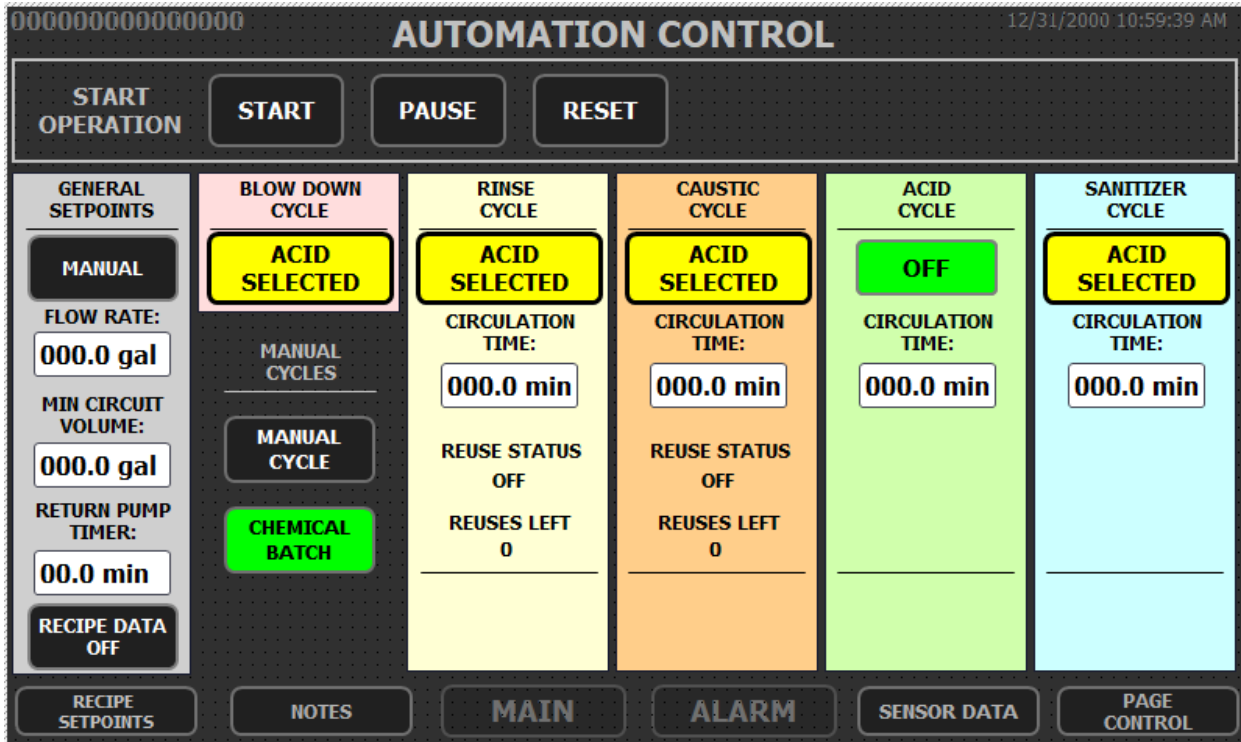

**If you press the start button with the above selections, the program will batch acid according to the setpoints on your chemical setpoints page. The program will not send this batch forward to a tank or other equipment.*

SYSTEM START

1. Verify all swing, hose or piping connections in the field are correct prior to starting a cycle.
2. Verify the **E-Stop** is not activated.
3. Verify no other CIP or calibration process is active
4. To initiate a wash cycle, press the **Automation Control** page button.
5. Verify correct recipe data is active if recipe data mode is activated.
6. To complete a manual cleaning cycle, select the **Auto/Manual** button to change to manual mode, then select **Manual cycle** followed by caustic, acid, or sanitizer cycle. Then press **Start Operation**
 - a. *Manual processes do not automatically complete post-rinse cycles.*
7. To complete a manual batch, select **Auto/Manual** button to change to manual mode, then select **Chemical Batch** followed by the desired chemical to batch. Then press **Start Operation**
8. To complete an automated cycle, de-select any manual starts if they were previously selected, make sure each cycle you would like to complete is selected "On", and then press **Start** in the start operation box at the top of the page
 - a. If a specific cycle is "off" the cycle will be skipped over to the next "on" cycle.
9. To **Pause** a cycle, press the **Pause** button located at the top of the page. To re-start, press the **Start** button. The system will automatically start at the beginning of the cycle it was paused on
10. **Reset** will stop the current cycle. When you re-start cleaning, it will go to the very beginning of the cleaning sequence.
11. After pausing or resetting a process, always verify it is ok to start a process again in the field. You may need to manually empty or rinse a tank or system before starting another cycle to prevent contamination or overfilling

12. Always verify current process has ended before moving to another

Maintenance

Warning! Make sure environment is safe before performing any maintenance on the system. Power to the control panel should be locked and control panel should be locked out. Other energy sources – steam, air, and water should be de-activated and locked out as well.

Warning! Always pre-rinse the system and wear appropriate PPE when opening any of the process lines or manways on the CIP system.

General cleanliness extends the life of your CIP skid components. The area should be kept clean of spills and debris. Never spray down the control panel.

If any hardware issues exist, place the system out of service until all the problems are resolved.

The y-strainers on the pump outlets should be checked and cleaned of debris *monthly*

It is recommended to go through this maintenance checklist every 6 months

1. Check air lines for cracks and leaks
2. Check air line connections to pneumatic valves for leaks
3. Check supply and return pump seals for wear or replace if noisy or seal failure
 - a. Extra Seals are available on the Deutsche Parts Website
<https://deutschebeverageparts.com/>
4. Check for loose wires within the control panel and at each instrument. Make sure all power is off, pull on wires at terminal and ensure a tight connection. Sometimes the vibration of the skid can loosen these connections over time
5. Tighten all tri-clamps and fittings on the skid. Drain any lines beforehand and wear necessary PPE just in case lines are not fully empty of chemical solution
6. Replace dosing pump suction and discharge tubing if needed. Chemical build-up can happen over time, restricting the pump and reducing dosing accuracy. Wear PPE! Recalibrate dosing pumps after replacing tubing. Tubing is available on our parts website
<https://deutschebeverageparts.com/>

Common Troubleshooting Steps

If a process fails to start, move to next step, or is out of sequence

1. Pause current process. If ok to start process over from beginning, press reset. Do not reset if trying to continue process from stopping point
2. Verify no other process is in progress
3. Reset flowmeter
4. Verify all valves are open in the field
5. Toggle tank auto-fill button
6. Restart process

Common Spare Parts

Check Deutsche Beverage Parts Website for all parts below

1. Spare chemical tubing – ½” ID PVC and ¼” ID hard polyethylene
2. Spare pumps seals – see parts website
 - a. SPX CIP Supply pump – C-Series – check pump for size or verify with Deutsche PM

- b. SPX CIP Return pump – Ws+ Series – check pump for size or verify with Deutsche PM
- 3. Dosing pump rebuild kits
 - a. Pulsatron K3VVC9 Rebuild Kit – Sani/PAA pump
 - b. Pulsatron K8PTCB Rebuild Kit – Caustic and Acid pumps
- 4. Dosing pump backpressure injection valves
 - a. Pulsatron J61237 injection valve – Sani/PAA pump
 - b. Pulsatron J61480 injection valve – Caustic and Acid pumps
- 5. 1.5" and 2" Tri-clamps, gaskets, sanitary hose, 2-1.5" reducers as necessary

For individual CIP skid component manuals, contact your Deutsche project manager, or call 704.900.6606

Deutsche employs a full service team to assist with any troubleshooting. Please contact 704.900.6606 and ask to speak to a member of our service department. If our team is busy, we can complete a service request form and respond to your request as soon as possible.